

**INSTALLATION INSTRUCTIONS**  
**MODEL TD SERIES UNDERSINK**  
**DO NOT PLUG IN OR TURN ON**  
**POWER**

**Step 1.** Position heater unit underneath the sink as close as possible to its outlet tap.

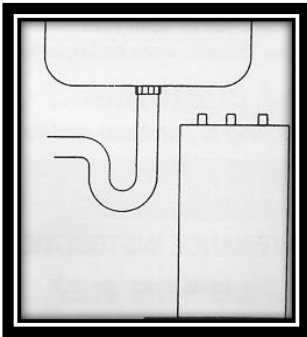

**Step 2.** Position the tap in the desired location. Drill 35 mm hole.

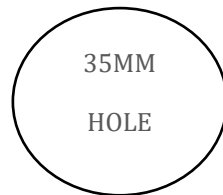

**INSTALLATION INSTRUCTIONS**  
**DO NOT PLUG IN OR TURN ON**  
**POWER**

**Step 3.** OBSERVING THE ATTACHED LABELS.

- A. Measure and cut pipes to desired length.
- B. Connect the Black 1/4" pipe from the tap to the inlet of the heater.
- C. Connect the Clear Tube 5/16" pipe (with clips) from the tap to the outlet of the heater.
- D. Connect the Blue 1/4" pipe from the tap to the water supply via an approved back flow device.
- E. Connect the flexible 1/4" Clear tubing from the tap to the vent pipe of the heater.

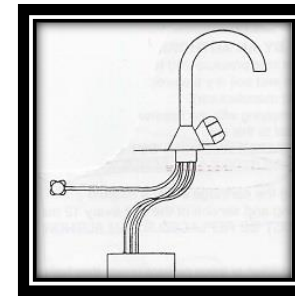

**Step 4.** All pipes and tubes must not be extended and must have continuous fall between tap and heater.

**Step 5.** OPEN TAP UNTIL WATER IS FLOWING FROM THE SPOUT.

**Step 6.** Plug unit into power point and switch on.

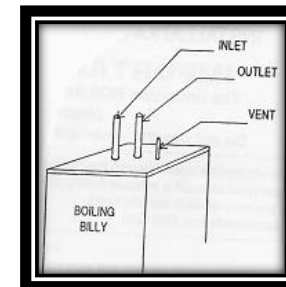

**UNIT MUST BE POSITIVELY EARTHED**

# TROUBLESHOOTING

Action only to be performed by a qualified person.

SYMPTON	CAUSES	ACTION
No Water	Water supply Turned Off Blocked Filter	Check main supply
Water not hot	Faulty element No power supply	Replace element Check and test power supply
Water overflowing from tap spout	Expansion chamber full Low inlet pressure	Run tap for 5-10 mins. This will correct water
Excessive Steam from Tap	Faulty Element	Replace Element

**N.B: These units are designed to have no less than 100ml of boiling water taken off at a time.**

PLEASE LEAVE THESE INSTRUCTIONS WITH THE OWNER

**DO NOT MEGGER**

**BEFORE USING WE RECOMMEND THE FITTING OF A WATER FILTER THAT IS WATERMARK APPROVED, FAILURE TO USE A FILTER WILL VOID WARRANTY.**

**ONLY TEFLON TAPE TO BE USED WHERE NECESSARY. UNDER NO CIRCUMSTANCES IS PLUMBERS PASTE TO BE USED.**

**To Plumber/User**

'Rapid Action tap 'factory set to average operating tension.

Gland nut may be adjusted (tighter- increased torque) to individual preference.

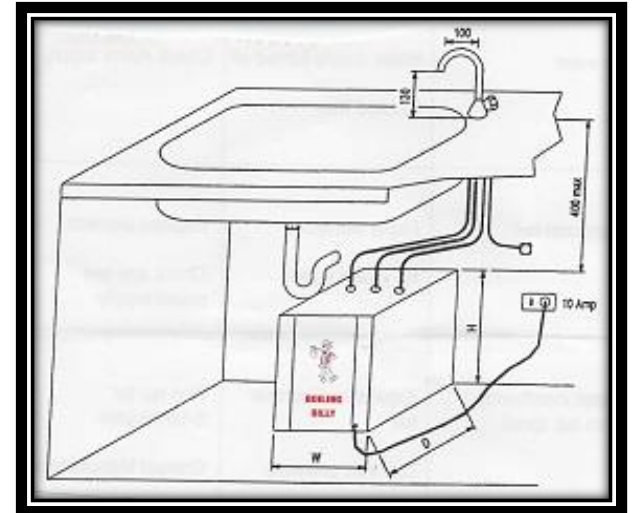

**TYPICAL INSTALLATION**

N.B When fitting this unit in a cupboard of small proportions, please note that the unit omit heat. If in doubt fit cross flow vents. **DO NOT** connect to hot water line-to do so will **VOID** warranty. **AFTER POWER IS ON-** allow 30 minutes before using.



LIC W359



# TD Series Undersink Instructions

**IMPORTANT PLEASE READ**

**WIFFEN PRODUCTS PTY LTD**

**Boiling Billy**



**This appliance is not intended for use by young children or infirm persons unless they have been adequately supervised by a responsible person to ensure that they can use the appliance safely.**

- Children being supervised not to play with the appliance**
- This appliance is intended to be used in household and similar working environments e.g. staff kitchen areas in shops, offices, farmhouses, and other working environments.**
- By clients in hotels, motels, bed, and breakfast type environments·**
- Ensure the power cable and power lead do not come into contact with liquids**
  
- Misuse of this product may cause harm or serious injury**

## To Our Valued Customer

A special Thank you for choosing to purchase and install our

### **TD SERIES UNDERSINK BOILING BILLY**

#### **INSTALLATION AND MAINTENANCE INSTRUCTION**

#### **IMPORTANT PLEASE READ**

**“The Undersink Boiling Billy” dispenses boiling water- please treat with care. Do not use the under sink for washing hands.**

**An authorised plumber must install units- unit must be connected in accordance with AS/NZS 3500.1 or AS/NZS 3500.4**

\*maximum inlet pressure- 650kpa-\* minimum inlet pressure- 280kpa

\*This unit is fitted with a computerized element and boil dry protection. The computer is set at 97degrees C.

\*Altitude will alter temperature (refer back to manufacturer)

**WARNING:** A backflow prevention device complying with the requirement of A.S 3500.1 is required to be installed on the water supply inlet to this unit.

- If fitted with filter we recommend changing the cartridge every 6 months.
- The manufacturer recommends the cleaning and service of the unit every 12 months.

#### **IF SUPPLIED CORD IS DAMAGED IT**

#### **MUST BE REPLACED BY AN AUTHORISED SERVICE AGENT**

#### **DO NOT SWITCH POWER ON UNTIL WATER RUNS OUT OF TAP.**

Do not regulate water flow with the tap. Have your plumber install a pressure limiting valve. If pressure exceeds manufacturers recommendations

For areas with pressure above 350 Kpa, an authorized 350 Kpa only pressure limiting valve must be fitted for maximum efficiency.

## **Contact Us**

1/33 Cedar Parade Moolap,  
Victoria

Phone: (03) 52487072

Email: sales@boiling-billy.com

Web: www.boiling-billy.com

Web: www.boiling-billy.com



**WIFFEN PRODUCTS PTY LTD**

A.C.N 073 810 616 A.B.N 95 073 810 616